

Cabling Systems for Next Generation Networking

Fanny Mlinarsky

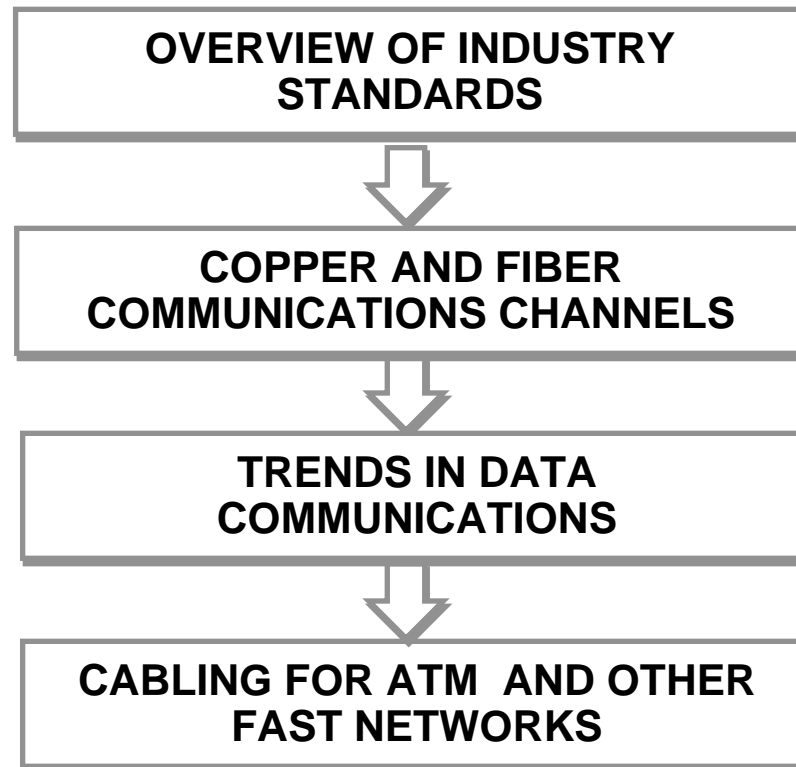

Industry Standards

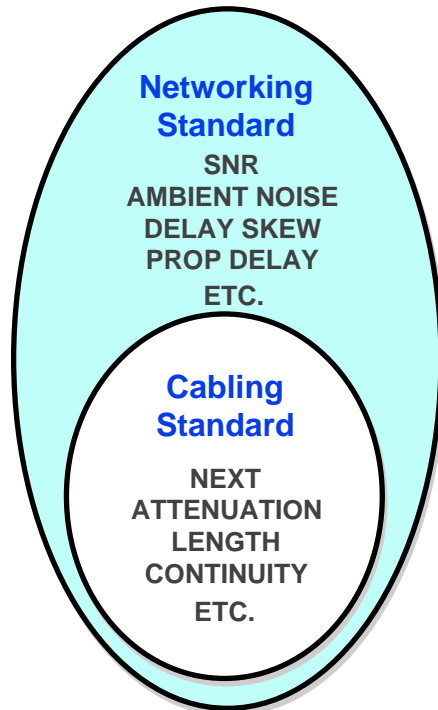

- **Network-specific standards**
 - ATM (12, 25, 51, 155 Mb/s)
 - 100 Mb/s “Fast” Ethernet
 - 100VGAnyLAN
 - 10Base-T, Token Ring
- **Generic cabling standards**
 - ISO 11801
 - » Classes B, C, D
 - TIA 568
 - » Categories 3, 4, 5
 - » TSB-67 Field Testing Standard



TIA-568-A Categories 3, 4 and 5 NEXT and Attenuation

CAT 3



CAT 4



CAT 5

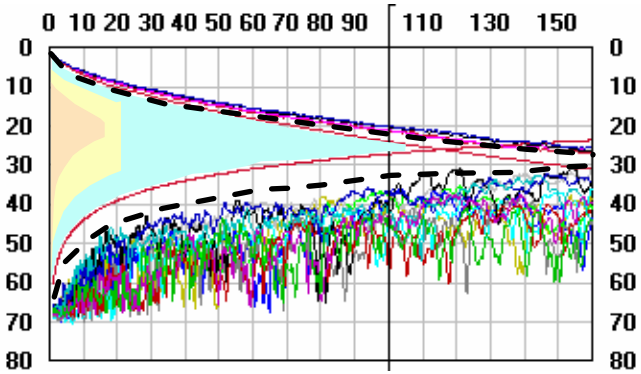
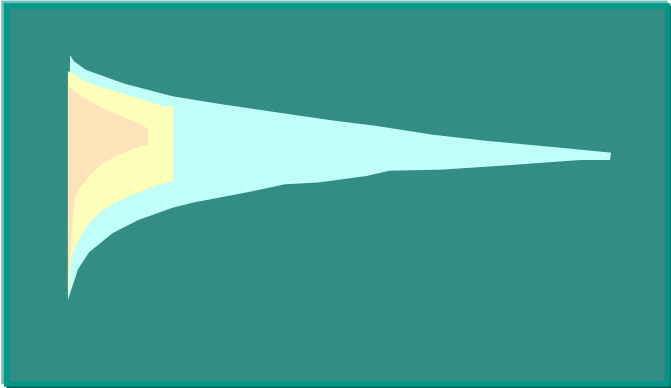

TIA-568-A Fiber Optic Link Attenuation

Attenuation
(dB)

Link with 2 connectors, no splices

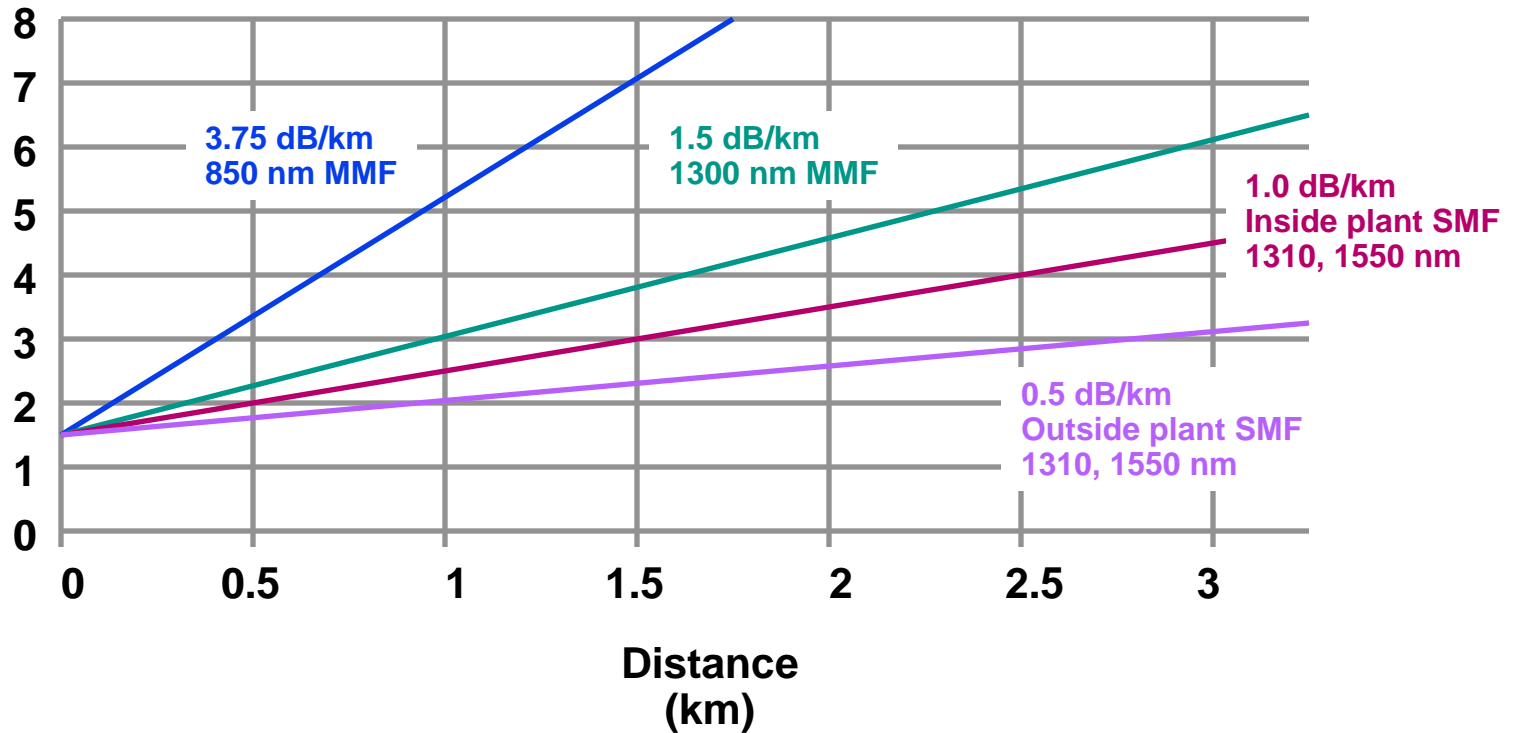

Category 3 Applications

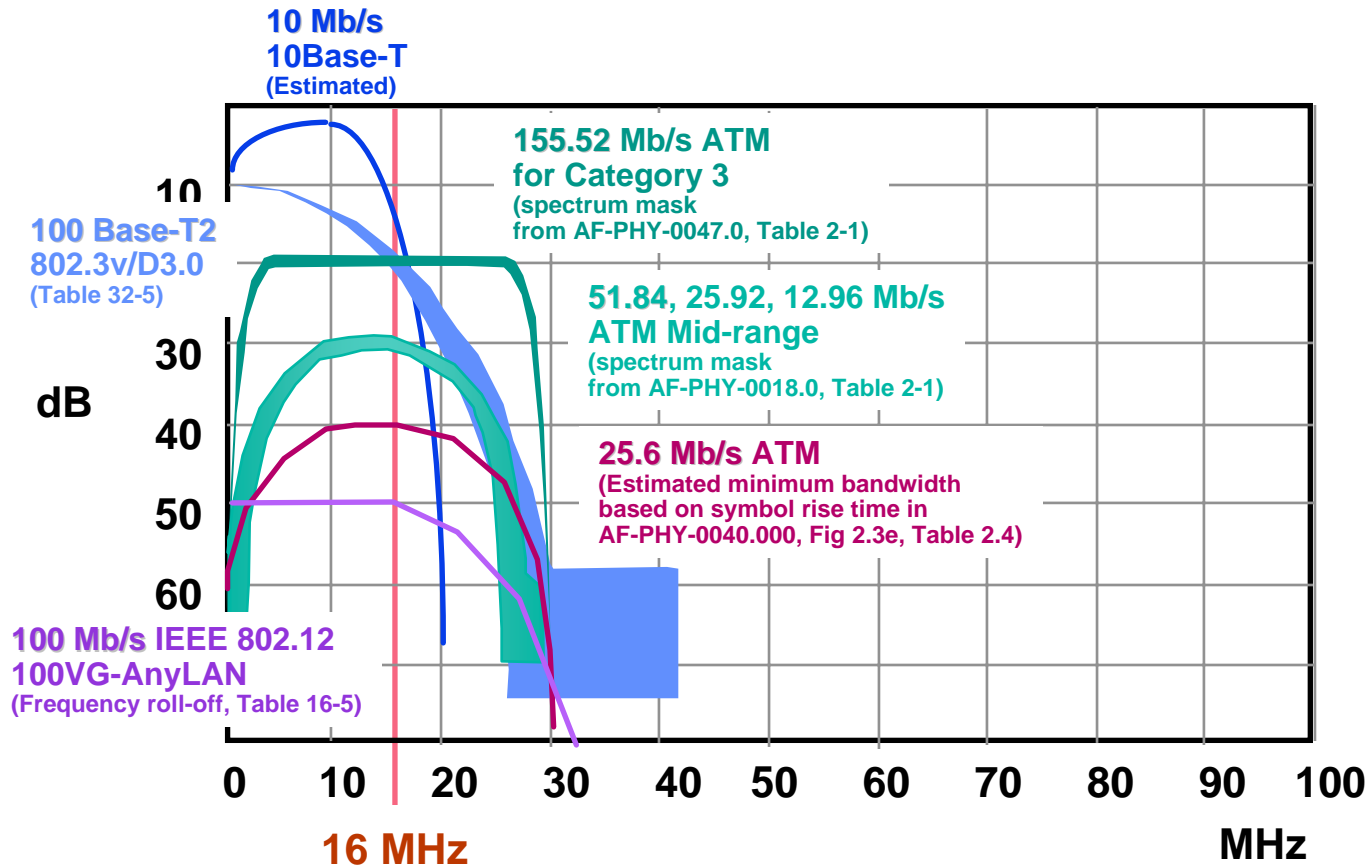

NOTE: All spectra are normalized; drawn at 10 dB offsets for clarity only

Category 5 Applications

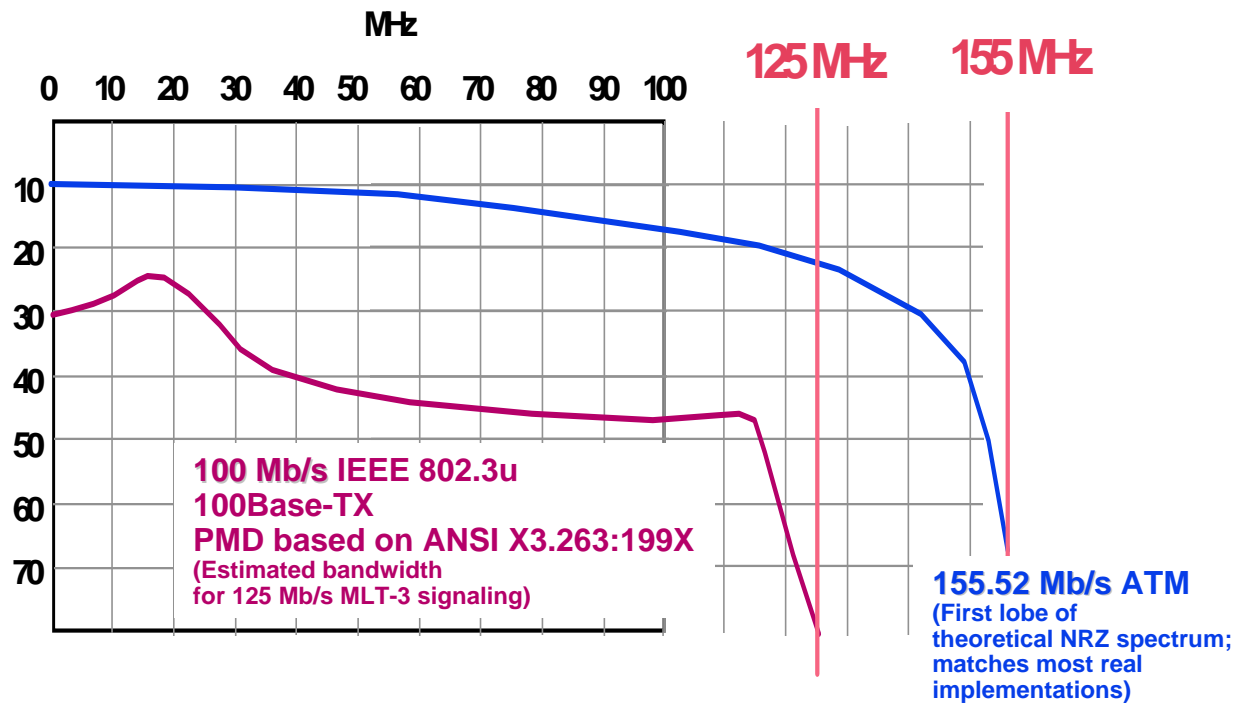

NOTE: Both spectra are normalized; drawn at 20 dB offset for clarity only

100 Mb/s 100Base-T4 Physical Layer Specs not covered by TIA-568-A or ISO 11801

- **100Base-T4, IEEE Std 802.3u-1995**
 - **Section 23.6.1: Category 3 or class C channel**
 - **Section 23.6.2.1: Insertion loss not to exceed 12 dB at 12.5 MHz**
 - » Inconsistent with cat 3 channel attenuation of 12.7 dB at 12 MHz
 - **Section 23.6.2.3.1: Max NEXT 24.5 dB at 12.5 MHz**
 - » Inconsistent with cat 3 channel NEXT of 21.1 dB at 12.5 MHz
 - **Section 23.6.2.3.2: Multiple Disturber NEXT (MDNEXT)**
 - » Not specified by TIA-568-A or ISO 11801
 - **Section 23.6.2.3.3: Equal Level Far-end Crosstalk (ELFEXT)**
 - » Not specified by TIA-568-A or ISO 11801
 - **Section 23.5.2.4.1: Max link delay 570 ns 2-12.5 MHz**
 - » Specified in TIA Draft 4 “Propagation Delay and Delay Skew Specifications for 100 ohm 4-pair Cabling”
 - » To be incorporated into the addendum to TIA-568-A
 - **Section 23.6.2.4.3: Max delay skew 50 ns**
 - » Specified in TIA Draft 4 “Propagation Delay and Delay Skew Specifications for 100 ohm 4-pair Cabling”
 - » To be incorporated into the addendum to TIA-568-A

100 Mb/s 100VG-AnyLAN Physical Layer Specs not covered by TIA-568-A or ISO 11801

- **100VG-AnyLAN, IEEE Std 802.12-1995**
 - **Section 16.9: Category 3 or class C channel**
 - **Section 16.9.1.1: Insertion loss not to exceed 14 dB at 15 MHz**
 - » Inconsistent with cat 3 channel attenuation of 14.4 dB at 15 MHz
 - **Section 16.9.1.3: Max link delay 5.7 ns/m, max 1.2 us total delay**
 - » Specified in TIA Draft 4 “Propagation Delay and Delay Skew Specifications for 100 ohm 4-pair Cabling”
 - » To be incorporated into the addendum to TIA-568-A
 - **Section 16.9.1.3: Max delay skew 67 ns**
 - » Specified in TIA Draft 4 “Propagation Delay and Delay Skew Specifications for 100 ohm 4-pair Cabling”
 - » To be incorporated into the addendum to TIA-568-A
 - **Section 16.9.3.1: Impulse noise >264 mV less than 0.2/sec**
 - » Not specified by TIA-568-A or ISO 11801

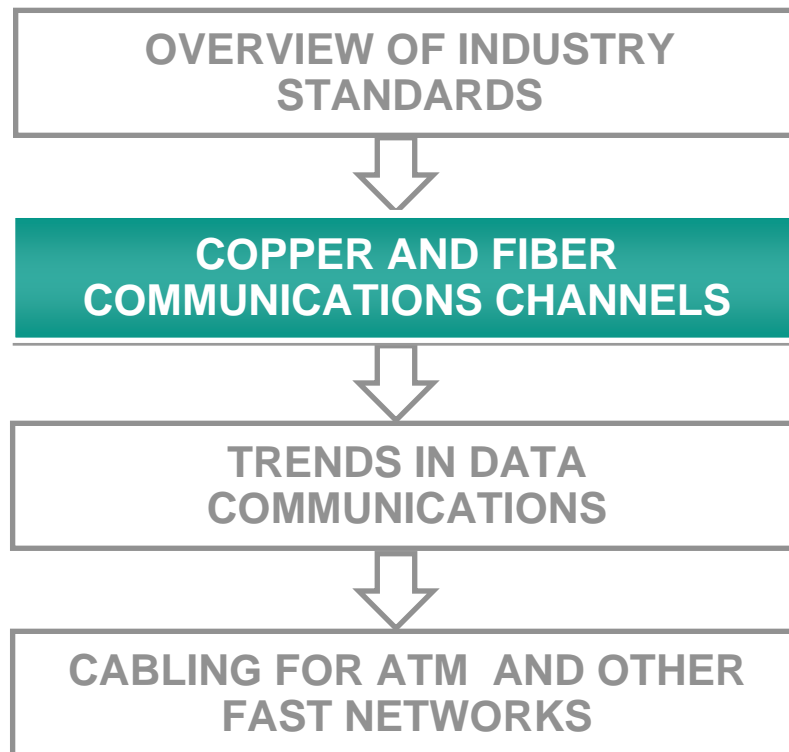

Twisted Pair Transmission

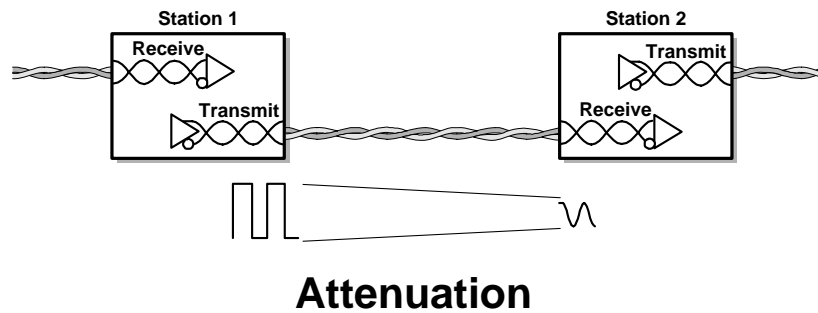
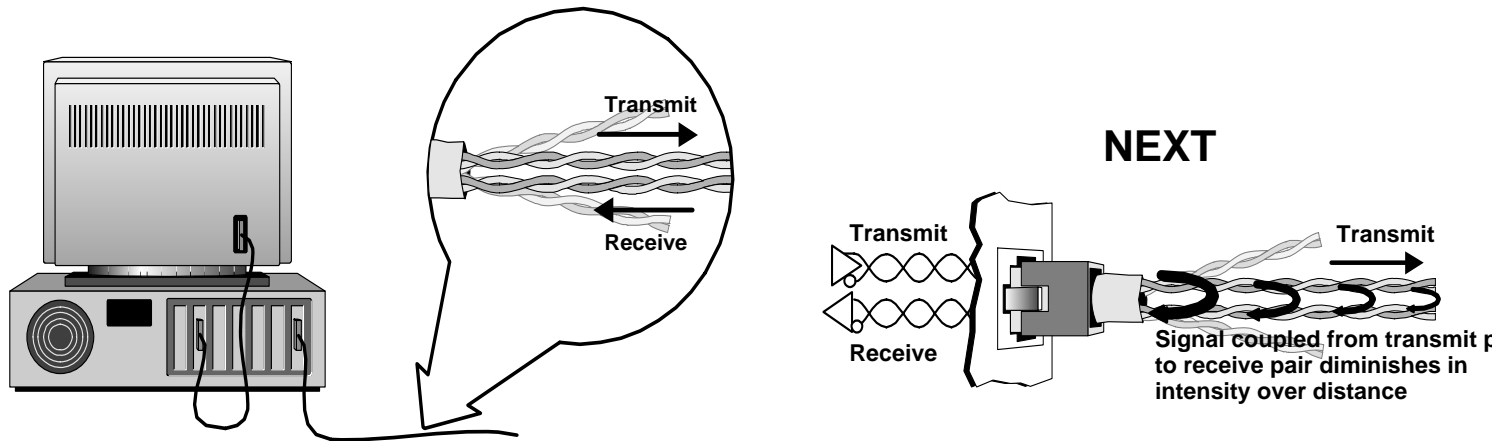

Twisted Pair Channel

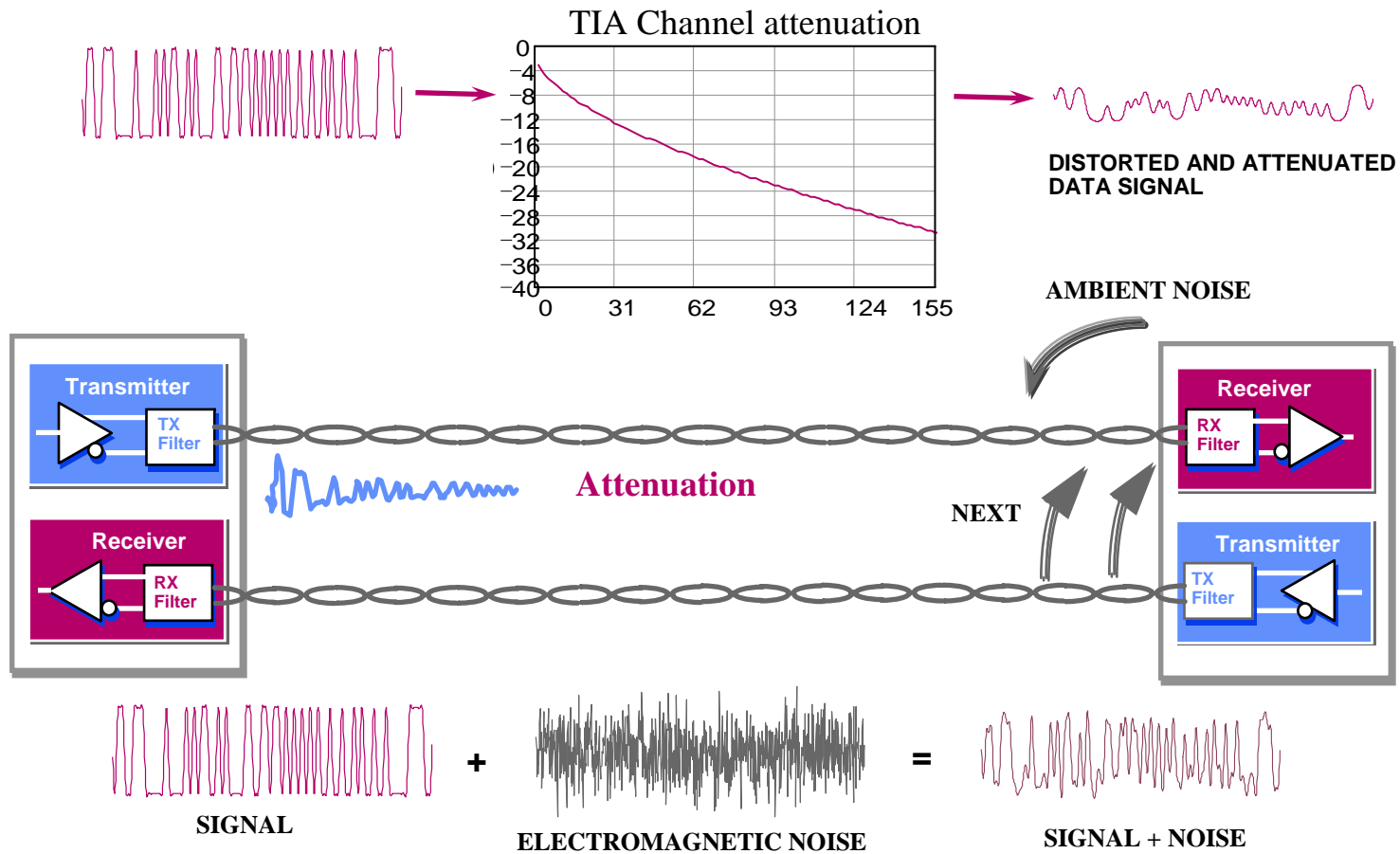

Fiber Optic Transmission

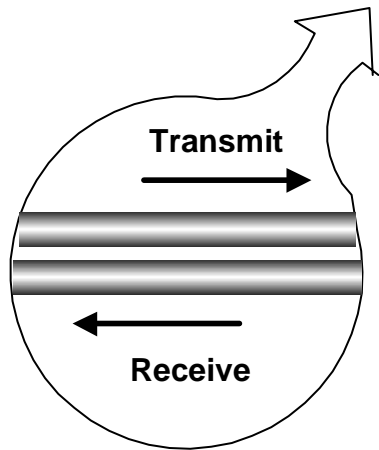
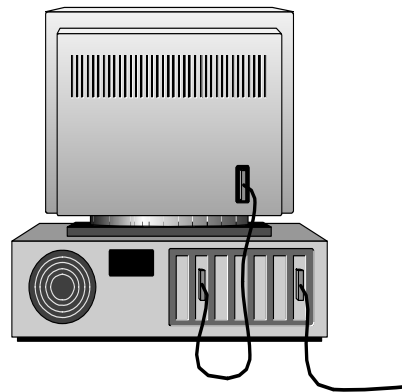

TRANSMITTER

LED
(850 or 1300 nm)
LASER
(850 or 1300)

Multi-Mode Fiber

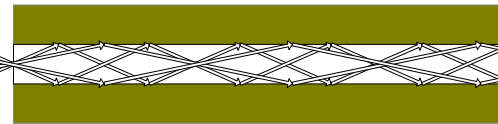

Core diameter is 50 or 62.5 μm graded index; allows multiple modes

DETECTOR

PIN
(P-intrinsic N)
APD
(Avalanche Photodiode)

TRANSMITTER

LASER
(1310 or 1550 nm)

Single-Mode Fiber



Core diameter is $< 10 \mu\text{m}$; allows only a single mode

DETECTOR

APD or PIN

Fiber Optic Channel Properties -- Attenuation and Dispersion

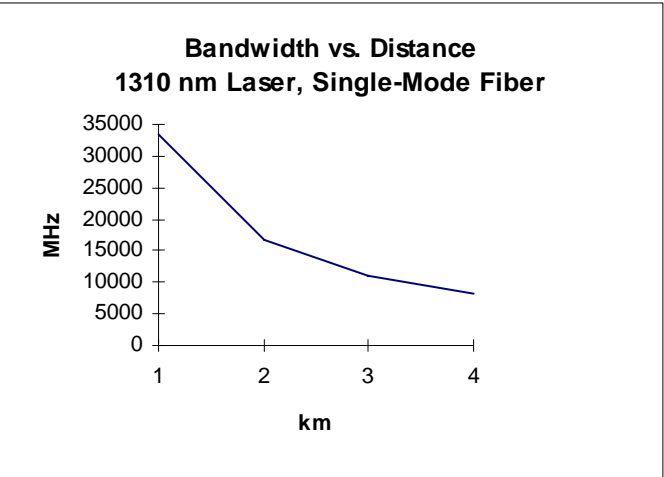
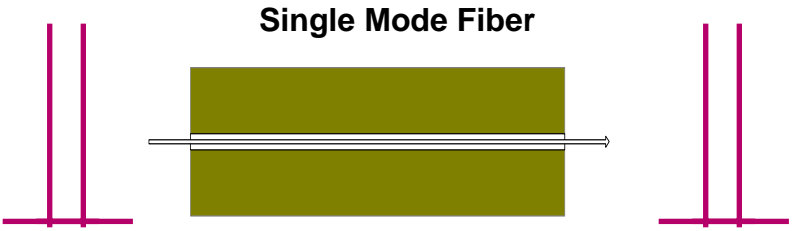
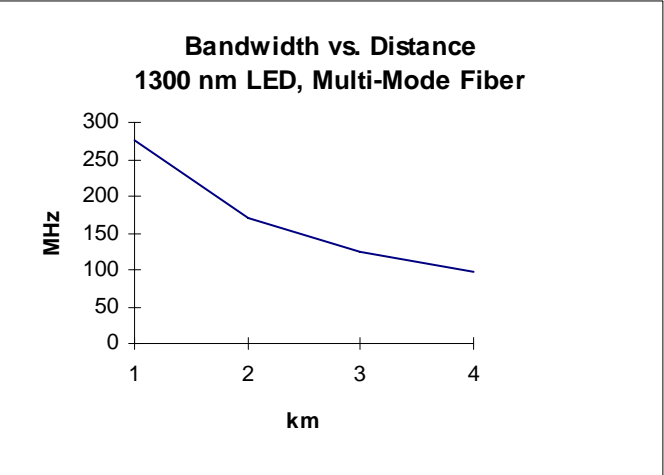
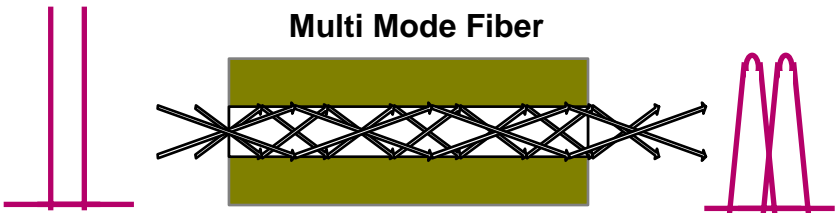

Fiber Optic Channel

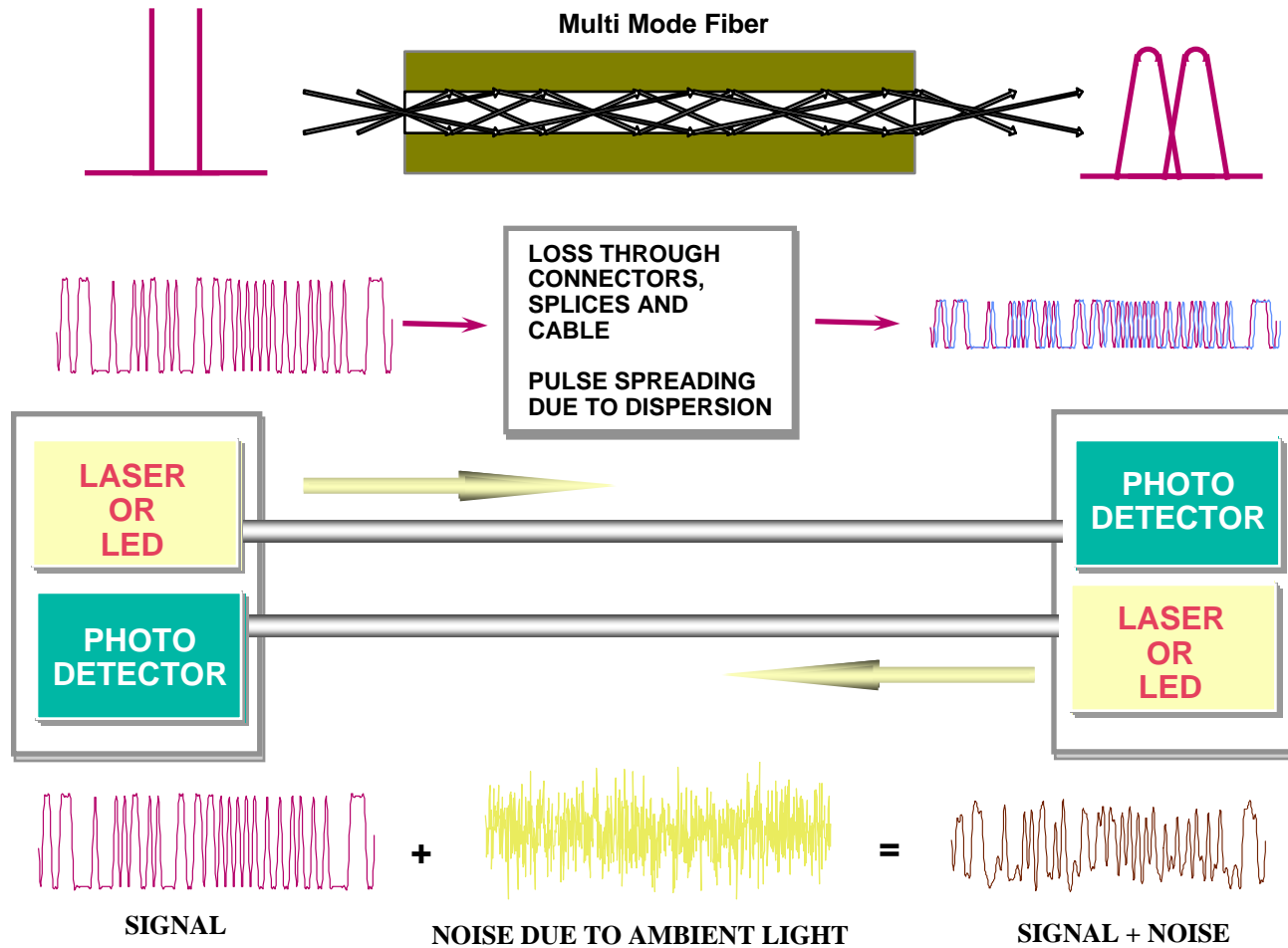

Bit Errors

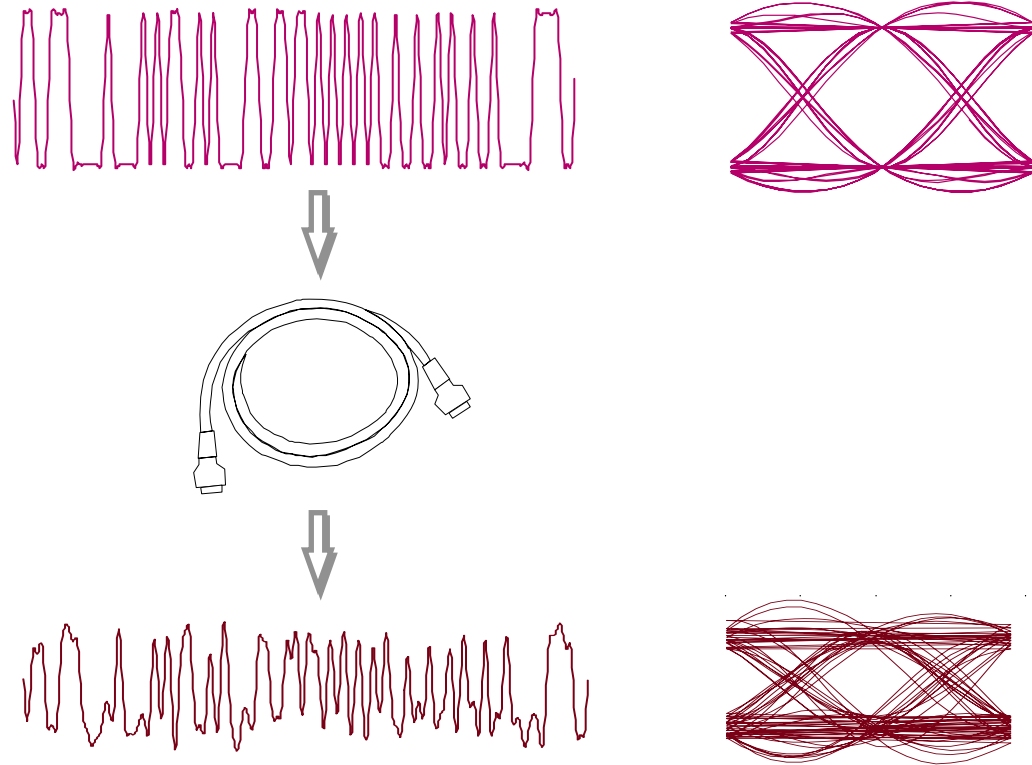

Bit Errors

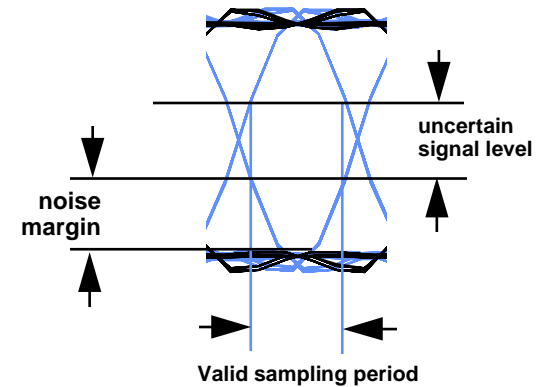
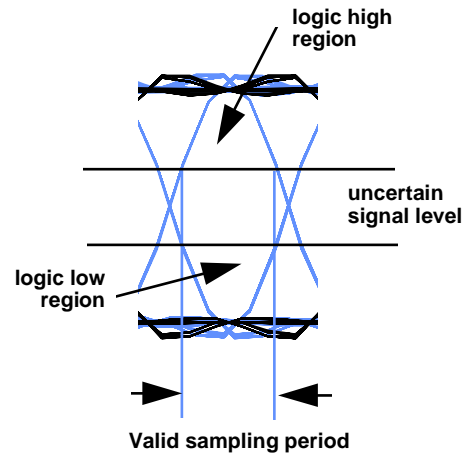

- Eye pattern opening determines the noise power needed to cause errors.
- The size of this opening is a good indication of the network robustness.

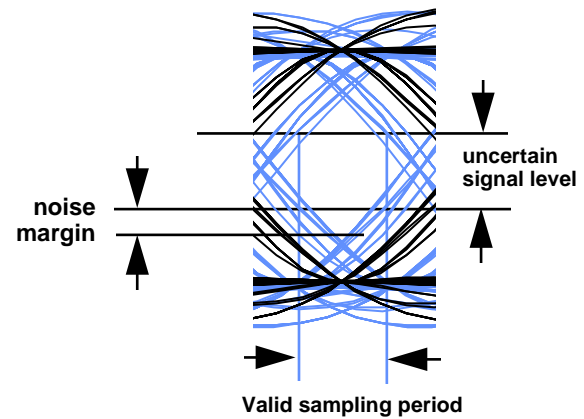

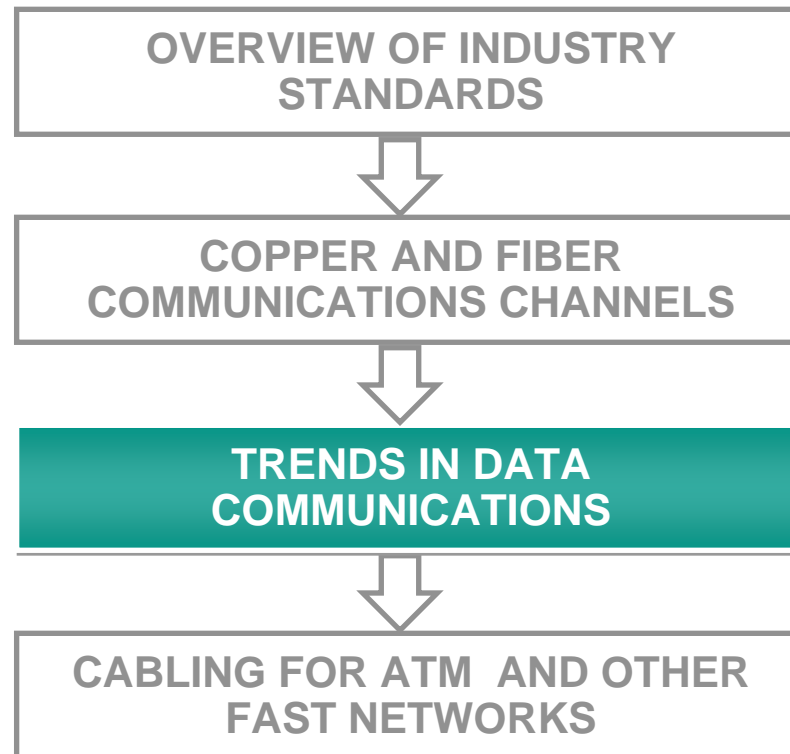

Today's Local Area Networks

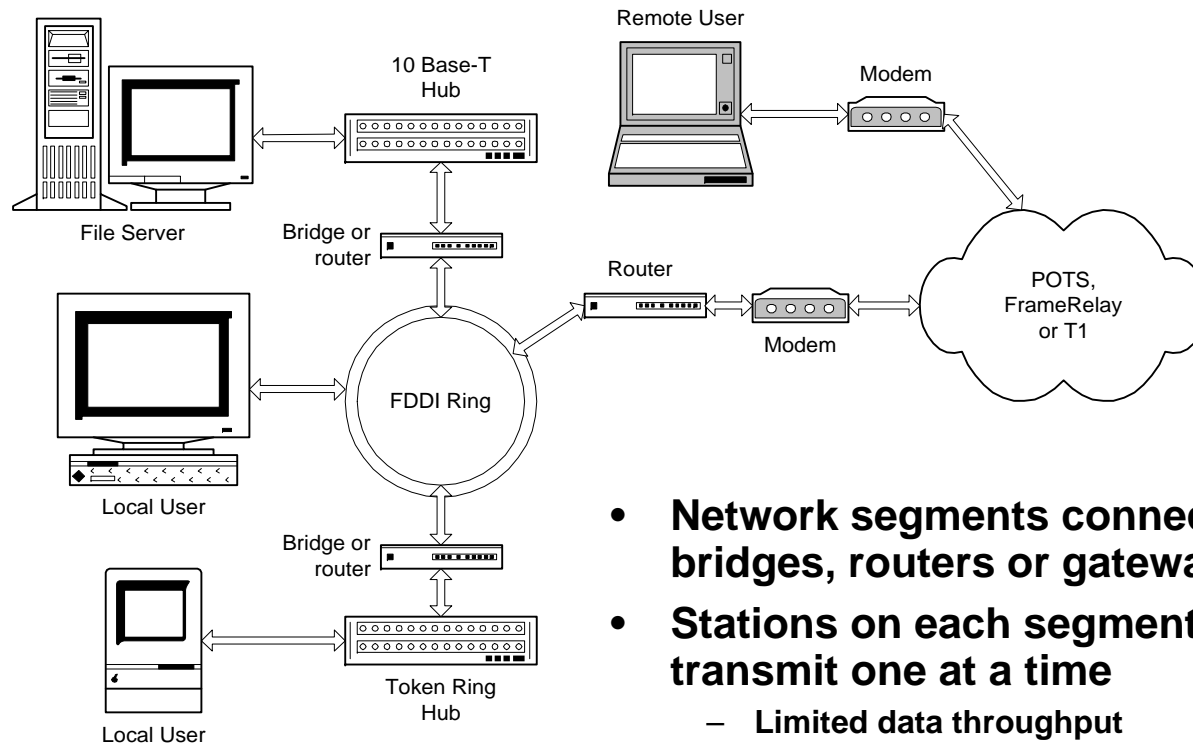

- **Network segments connected by bridges, routers or gateways**
- **Stations on each segment can only transmit one at a time**
 - Limited data throughput
- **Modem connection to remote sites**

Trends in Data Communications

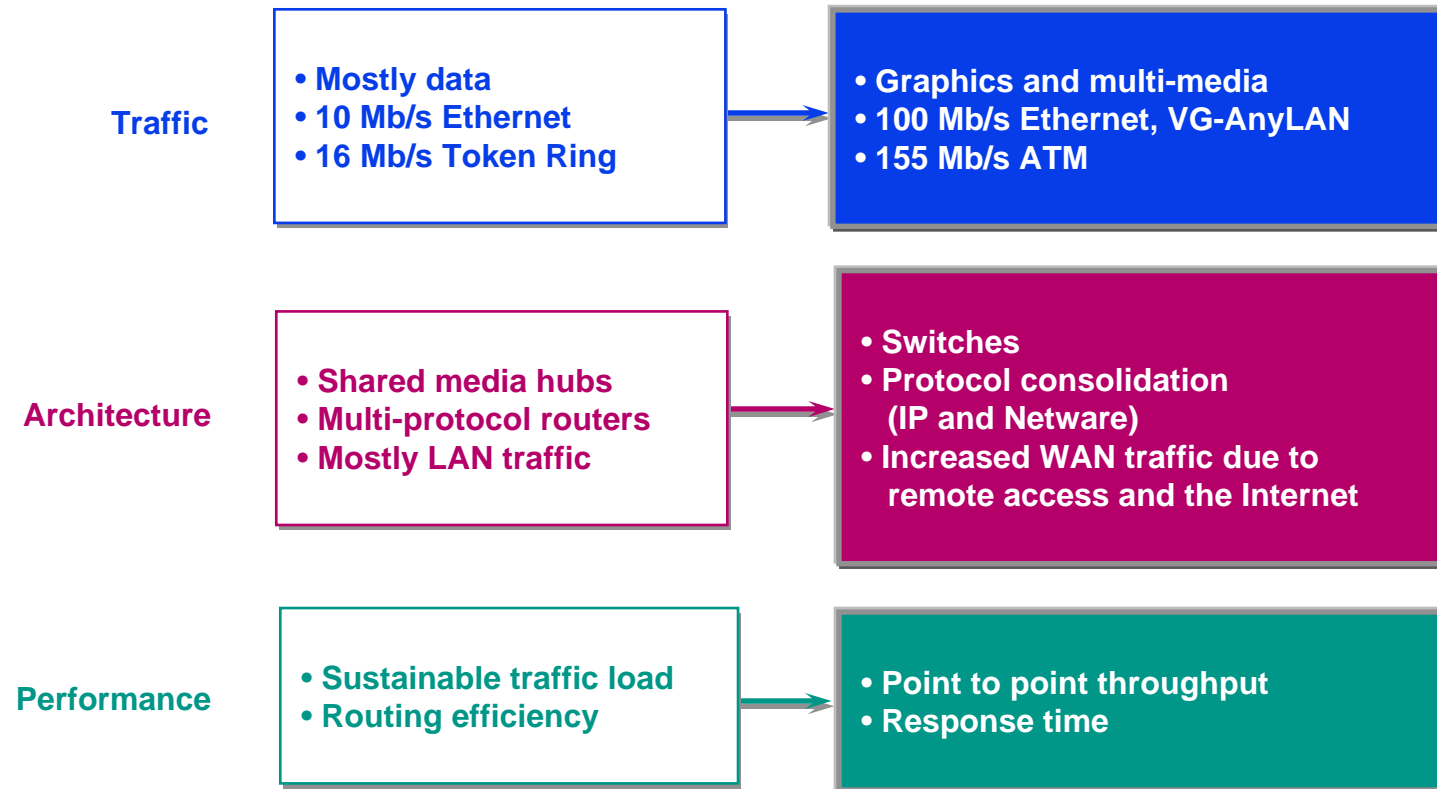

Next Generation Networks

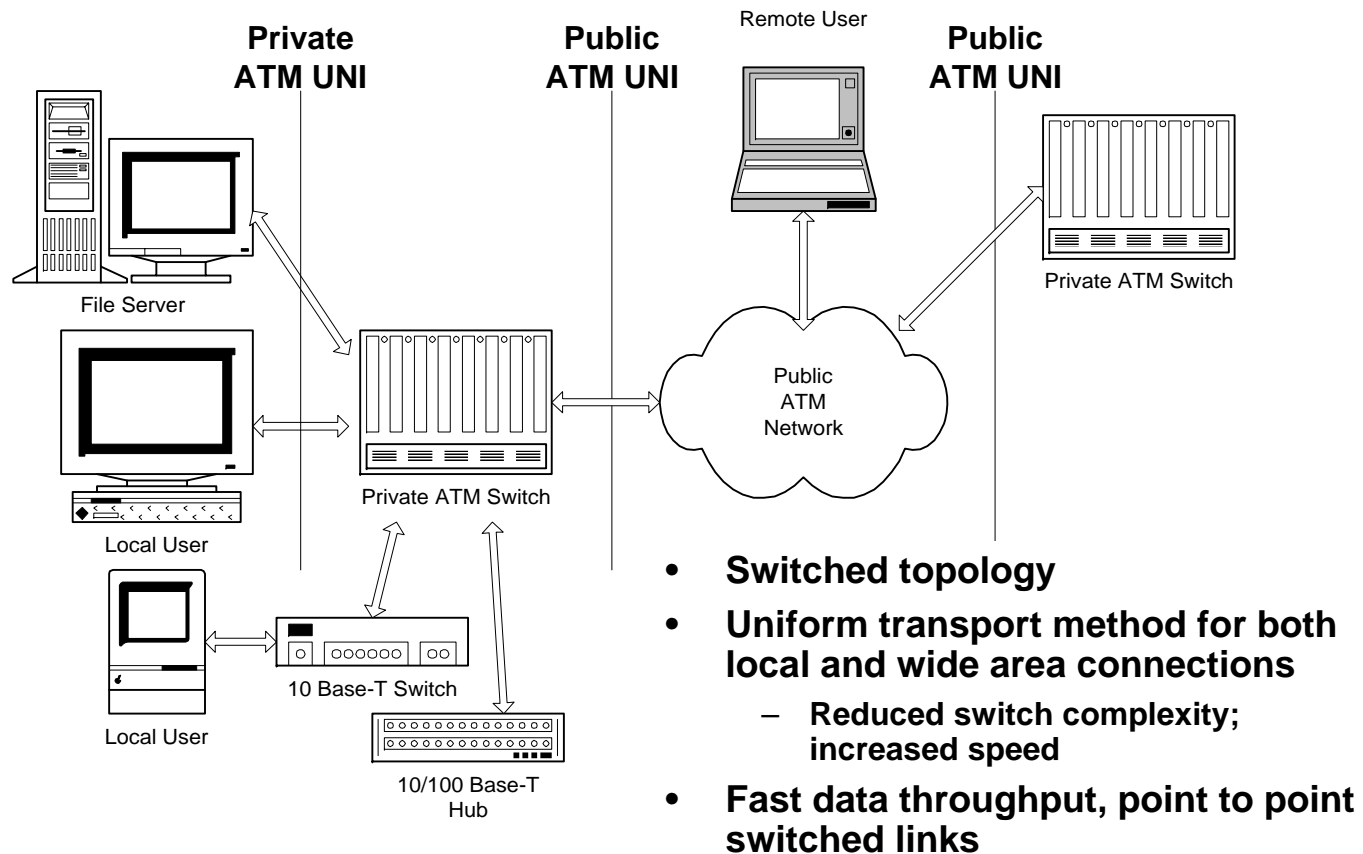

Note: UNI = User-to-Network Interface



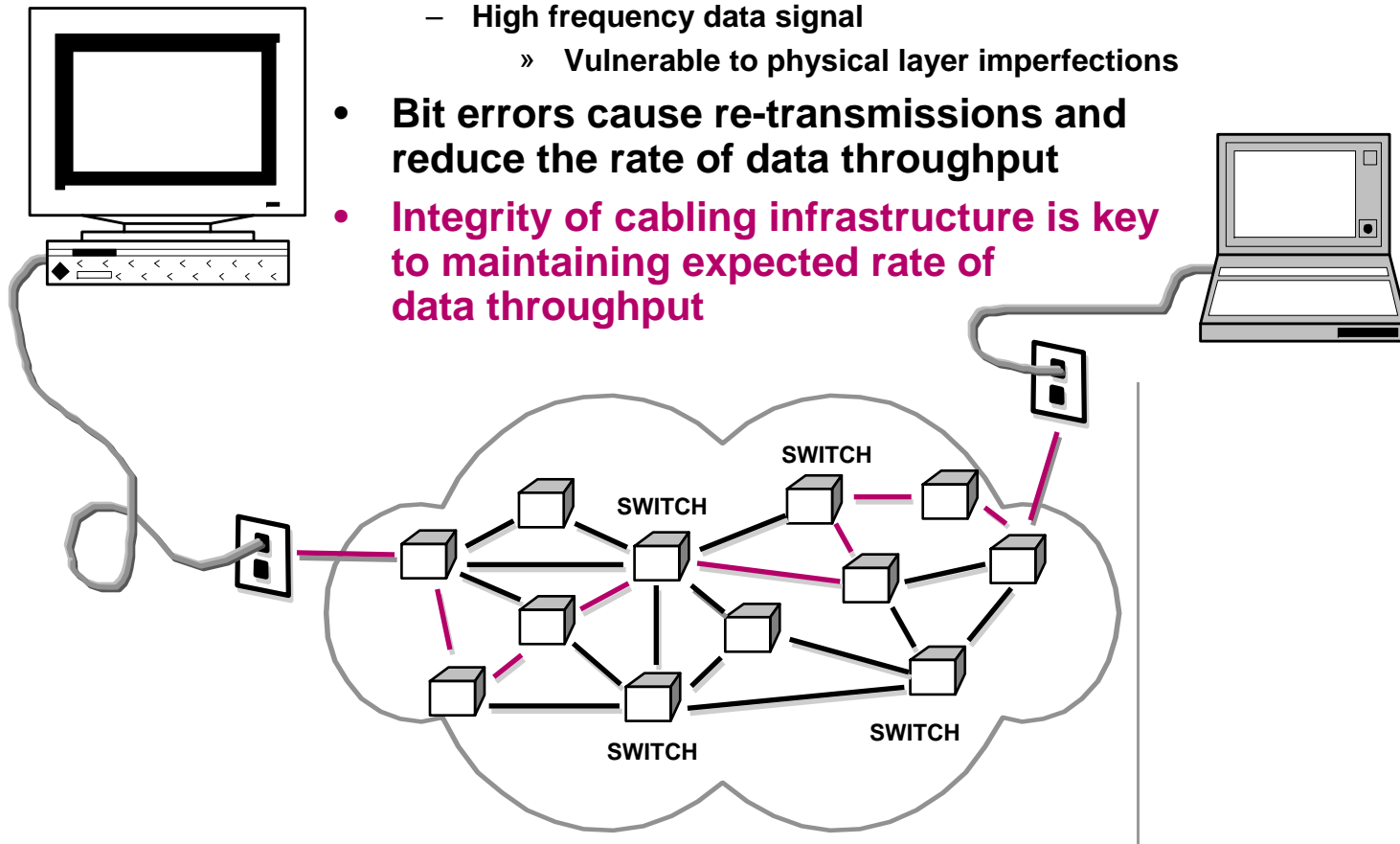

Performance Metrics for Next Generation Networks

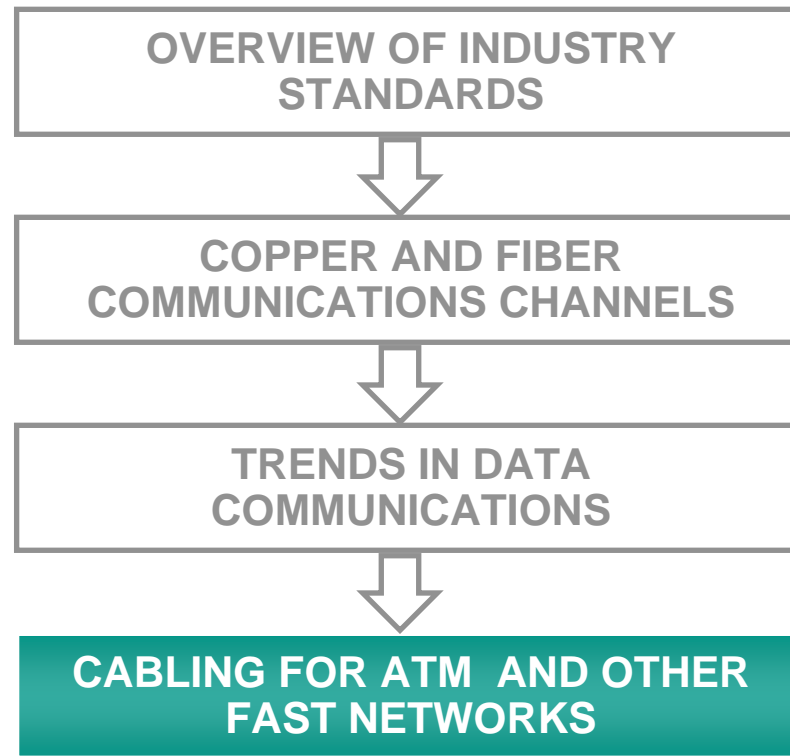
- **Emphasis on high rate of point to point data throughput**
 - High frequency data signal
 - » Vulnerable to physical layer imperfections
- **Bit errors cause re-transmissions and reduce the rate of data throughput**
- **Integrity of cabling infrastructure is key to maintaining expected rate of data throughput**





ATM Physical Layer Interfaces

INTERFACE	DATA RATE (Mb/s)	LINE RATE (Mbaud)	PHYSICAL LAYER	STANDARD
622.08 Mb/s (SONET STS-12c based)	622.08	622.08	SMF, 1300nm, 2 or 15 km MMF, 1300nm LED, 500 m MMF, SW Laser, 300 m	AF-PHY-0046.000
155.52 Mb/s (SONET, STS-3c based)	155.52	155.52	MMF, 1300 nm SMF, 1300 nm	AF-BICI-0013.003, TR-NWT-000253
DS3	44.736	44.736	75 Ohm Coax	AF-PHY-0054.000 (Ballot)
DS1	1.544	1.544	100 Ohm UTP	AF-PHY-0016.000
E4	139.264	139.264		UNI v3.1, ITU-T G.703
E3	34.368	34.368	75 Ohm Coax	UNI v3.1, ITU-T G.703
E1	2.048	2.048	120 Ohm STP, 75 Ohm Coax	AF-PHY/94-0422R7 (straw vote)
100 Mb/s FDDI-PMD	100	125	SMF, MMF, 1300 nm	UNI v3.1, ISO/IEC 9314-3
155.52 Mb/s (8B/10B) (Fiber Channel based)	155.52	194.4	MMF, 1300 nm, 2 km 150 ohm STP, 100 m	UNI v3.1
155.52 Mb/s POF/HPCF *	155.52, 50	155.52, 50	MMF, 650 nm, 50 / 100 m	Proposal
 155.52 Mb/s SW Laser	155.52	155.52	MMF, 850 nm, 1 km, TIA-568	AF-PHY-0062.000 (Ballot)
 155.52 Mb/s Cat 5 UTP	155.52	155.52	Cat 5 UTP, TIA-568 Channel	AF-PHY-0015.000
 155.52 Mb/s Cat 3 UTP	155.52	25.92	Cat 3 UTP, TIA-568 Channel	AF-PHY-0047.000
 Mid-range Phy, Cat 3 UTP	51.84, 25.92 12.96	12.96	Cat 3 UTP, TIA-568 Channel	AF-PHY-0018.000
 25.6 Mb/s, Cat 3	25.6	32	Cat 3 UTP, TIA-568 Channel	AF-PHY-0040.000

155.52 Mb/s Category 5 ATM Physical Layer

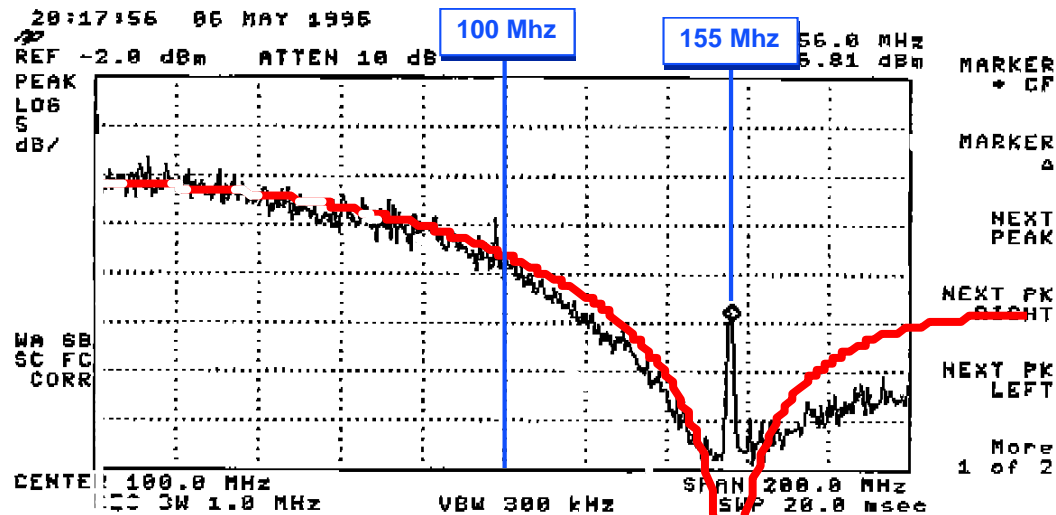

- 155 Mb/s ATM equipment, based on ATM Forum AF-PHY-0015.000 specification, has the transmit spectrum extending to 155 MHz
- It is a good idea to characterize channels expected to carry 155 Mb/s ATM to 155 MHz

155 Mb/s BER TEST Channel Certification Results

Channel NEXT
and attenuation;
no filtering
BER:
 2.1×10^{-11}
 3.9×10^{-11}

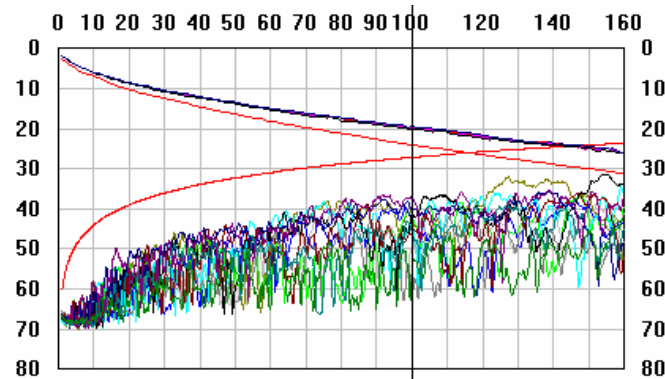

Channel NEXT
and attenuation;
with a notch
BER:
 6.1×10^{-10}
 7.8×10^{-10}

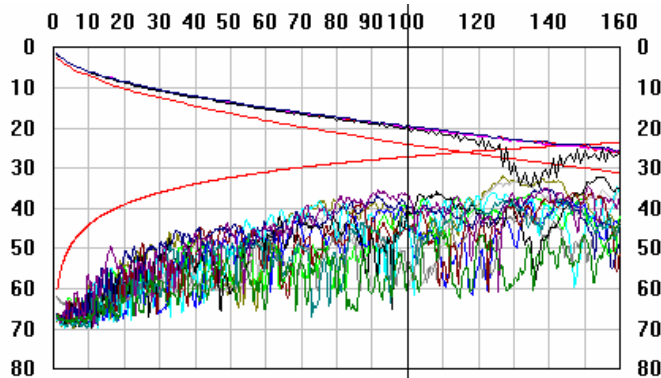

Channel NEXT
and attenuation;
With a stub
BER:
 1.2×10^{-8}

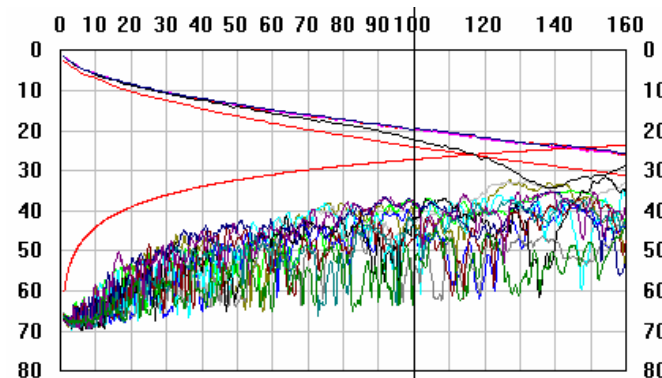

Importance of Energy Above 100 MHz to 155 Mb/s ATM Operation -- Example

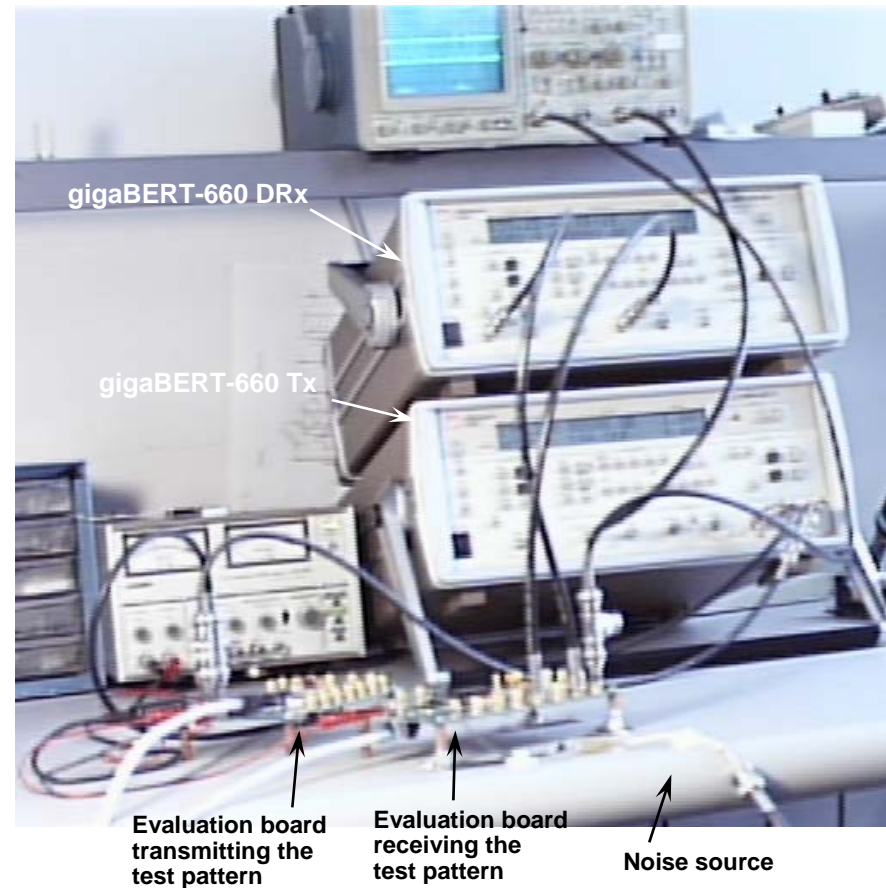

155 Mb/s ATM Physical Layer Requirements

- The 155 Mb/s ATM interface (AF-PHY-0015.000) uses the twisted pair channel beyond the frequency range specified by TIA-568-A and ISO-11801 and relies on the extended frequency response of the channel for maintaining the required BER performance of 10^{-10} .
- This service works only because most category 5 installations behave predictably above 100 MHz.
- Using components beyond their frequency specification is a poor design practice -- it leaves the system vulnerable to new products which might employ emission suppressing filtering and to installation flaws which might be outside the specified frequency range.

Mid-range Twisted Pair ATM Physical Layer

- ATM Forum AF-PHY-0018.000, 9/94; AF-PHY-0047.000
- Spectral width and line rate of 12.96 Mbaud are the same for all data rates
 - 155.52 Mb/s 64-CAP (Carrierless AM / PM)
 - 51.84 Mb/s 16-CAP
 - 25.92 Mb/s 4-CAP
 - 12.96 Mb/s 2-CAP

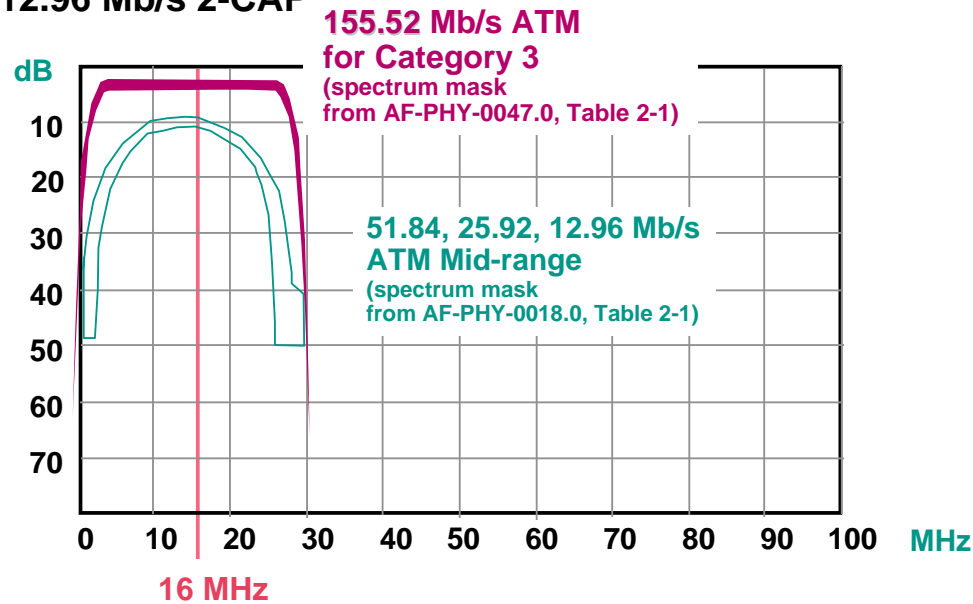

Mid-range Twisted Pair ATM Physical Layer

- **Template for the power spectrum of a Mid-range ATM device is specified in AF-PHY-0018.000 Figure 2-8 and Table 2-1**
 - Spectrum centers around 12.96 MHz and has 100% excess bandwidth, extending to **25.92 MHz**
- **Template for the spectrum of 155.52 Mb/s service specified in AF-PHY-0067.000 Figure 2-6 and Table 2-1**
 - Spectrum centers around 25.92 MHz and has 15% excess bandwidth, extending to 29.8 MHz
- **Transmitter and receiver return loss for both services is specified in the frequency range **1-30 MHz** to be >15 dB**
- **If it is important to maintain return loss of 15 dB at the device, then the cable needs to behave consistently in the range of 1-30 MHz as well**
 - Inconsistent with the 16 MHz range of category 3 specification
- ↓ **Good idea to verify channel NEXT and attenuation beyond the category 3 range of 16 MHz**
 - **Field test range should extend to 26 MHz minimum**

25.6 Mb/s Twisted Pair ATM Physical Layer

- ATM Forum document AF-PHY-0040.000, 11/95
- Line rate is 32 Mbaud after 4B5B encoding (Section 2.1.1)
- Spectrum is not specified directly but can be estimated from the rise time of a One Symbol Element template in Figure 2.3e and Table 2.4

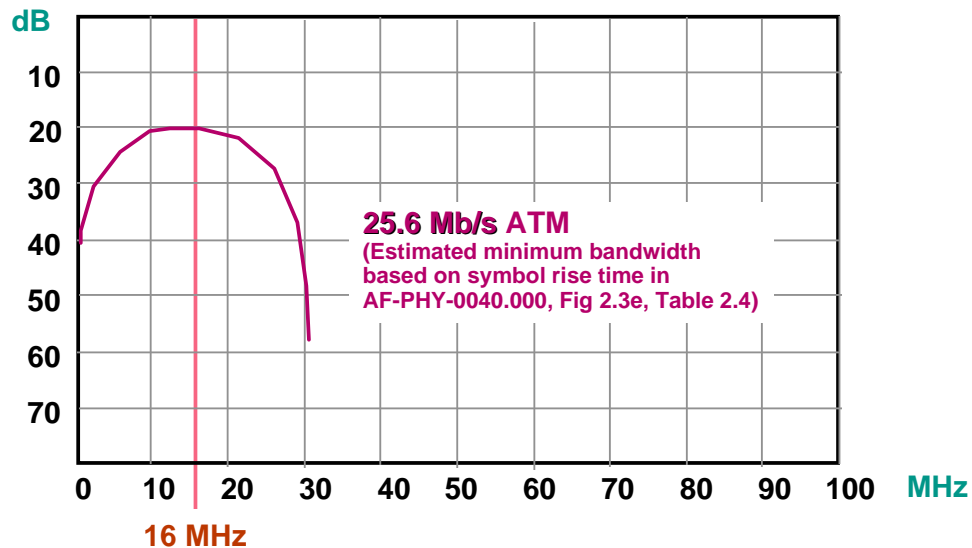

25.6 Mb/s Twisted Pair ATM Physical Layer

- **Sections 2.2.4 and 2.3.2 specify transmitter and receiver return loss in the frequency band of 1-25 MHz**
 - Transmitter 1-6 MHz 14 dB, 6-17 MHz 12 dB, 17-25 MHz 8 dB
 - Receiver 1-17 MHz 15 db, 17-25 MHz 8 dB
- **If it is important to bound return loss at the device up to 25 MHz, then the cable should be characterized up to 25 MHz as well**
 - Inconsistent with the 16 MHz range of category 3 specification
- ↓ **Good idea to verify channel NEXT and attenuation beyond the category 3 range of 16 MHz**
 - Field test range should extend to 25 MHz minimum

10/100 Base-TX Physical Layer

- IEEE Std 802.3u-1995, Chapter 25, refers to TP-PMD standard, ANSI X3.263, 3/95, for category 5 UTP and 150 ohm STP interfaces
 - TP-PMD standard specifies
 - 100 Mb/s using 4B/5B encoding to produce 125 Mb/s data stream
 - Multi-Level Transmission-3 (MLT-3) modulation
 - » 3 voltage levels with the spectral peak at around 30 MHz
 - » Return loss of transmitter and receiver is specified (Sections 9.1.5 and 9.2.2) up to **80 MHz**
 - Ranging from 16 to 10 dB as frequency increases
 - Insertion loss deviation (Sections 11.1.5) 0.35 dB max
 - » This specification ensures consistent attenuation slope over frequency and ensures integrity of Structural Return Loss (SRL)
 - Maximum medium propagation delay, IEEE Std 802.3u-1995 Table 29-1
 - Twisted pair link 1140 ns
- ↓ **Category 5 certification with additional measurement of propagation delay is sufficient field verification**

155.52 Mb/s Short Wavelength Laser ATM Physical Layer

- ATM Forum AF-PHY-0062.000, Letter Ballot, 5/96
 - TIA-568-A or ISO 11801 compliant Multi-Mode Fiber installation
 - Cable plant attenuation
 - < 7.2 dB for 62.5 μ m
 - Distance
 - 1 km
 - Line code
 - Optical NRZ, 152.52 MBaud
 - Laser wavelength
 - 770 to 860 nm
 - Full Width Half-Maximum (FWHM) spectral width
 - 9 nm
- ↓ Field verification of attenuation budget at 850 nm is sufficient

10/100 Base-FX Physical Layer

- IEEE Std 802.3u-1995, Chapter 26 refers to the FDDI PMD, ISO 9314-3 for the fiber physical layer specification
- ISO 9314-3 specifies the following fiber interfaces
 - Single-Mode Fiber
 - Multi-Mode Fiber, 2 km
 - MMF, 500 m Low Cost Fiber (LCF-PMD)
- Wavelength 1300 nm
- Symbol rate 125 Mbaud
- Maximum propagation delay, 802.3u-1995, Table 29-1
 - Fiber link 4120 ns
- ↓ **Field test should include verification of**
 - Attenuation
 - Propagation delay

