

Broadband 101: Installation and Testing

Fanny Mlinarsky

Introduction

Today the Internet is an information superhighway with bottlenecks at every exit. These congested exits call for the deployment of broadband access to the homes and businesses. Broadband technology lets you watch TV (video), browse the Internet via a high-speed connection (data) and use the phone (voice) simultaneously. Broadband access means support for data, voice and video services over a single cable with an “always-on” connection (i.e. no dial-up required).

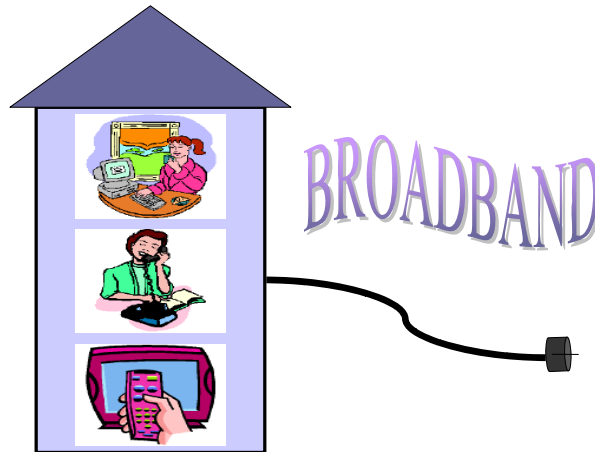

Figure 1: Broadband access supports high-speed data, voice and video services over the same physical connection letting you talk on the phone, watch digital TV and browse the Internet simultaneously.

Broadband access is primarily deployed via HFC (hybrid fiber coax) or DSL (digital subscriber line) installations. HFC is a residential technology and is brought into the home as a 75-ohm coaxial cable carrying cable TV, phone and Internet access services. Internet access via HFC is accomplished using cable modems. DSL access provides data, voice and video services over the familiar telephone installations. Within local premises, Ethernet is the data network technology of choice used to interconnect workstations, servers and other network resources on a LAN (local area network).

The demand for broadband access is definitely ahead of its deployment. Most of us still connect to the Internet through dial-up lines. While we wait for slow-loading web pages, we yearn for more bandwidth and the “always-on” connectivity of broadband access. Broadband services are now being deployed but will take some time to reach a significant portion of the population. Meanwhile, installers would do well to get educated on the new broadband technologies such as DSL and HFC and the installation and testing issues associated with their deployment.

DSL

Digital Subscriber Line (DSL) is the solution for providing broadband services over the existing telephone connections. DSL data flows between Central Office and user premises. The “upstream” direction of data flow is from the user premises to the Central Office. The “downstream” direction is from the Central Office to the user.

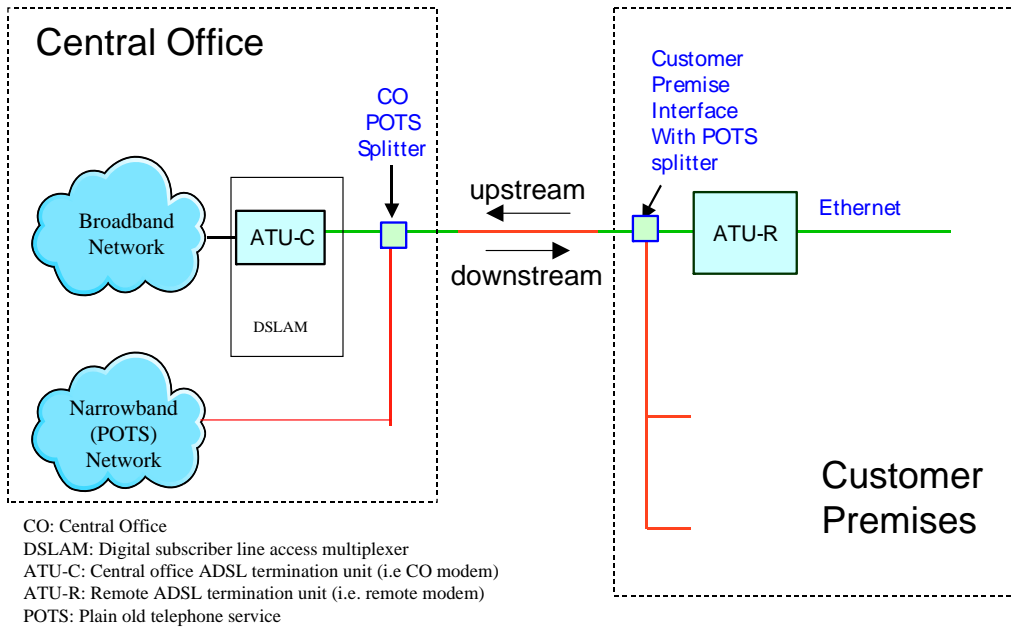

Figure 2. Typical DSL architecture. This figure shows a 1-pair ADSL circuit. The splitters are required to carry traditional analog telephone and data on the same pair. The data flowing from the customer to the CO flows upstream. The data flowing from the CO to the customer flows downstream.

Different DSL technologies offer a range of data rates and modes of operation (table 1). Symmetric technologies (ISDN, HDSL, and SHDSL) operate at the same data rate in the upstream and downstream directions. The primary application for symmetric DSL is T1, used by businesses. Asymmetric technologies (ADSL, VDSL) operate at different upstream and downstream data rates and are used primarily by residential customers for Internet access. Asymmetric transmission maximizes the bandwidth to the user in order to speed up common download and streaming audio and video operations performed during web browsing.

Table 1 – DSL Technology Family

Name	Meaning	Data Rate	Mode	Distance (max. copper length)	Applications
ISDN	Integrated services data network	160 kbps ¹	Symmetric (1 pair)	Up to 12,000 ft.	Voice and Data
HDSL	High data rate digital subscriber line	1.544 Mbps 2.048 Mbps	Symmetric (2 pairs)	Up to 12,000 ft.	T1/E1 service voice, data
SHDSL or SDSL	Single line digital subscriber line	768 kbps-1.544 Mbps 1.024 Mbps – 2.048 Mbps	Symmetric (1 pair)	Up to 12,000 ft	Same as HDSL
ADSL	Asymmetrical digital subscriber line	1.5 – 9 Mb/s 16 – 640 kbps	downstream upstream (1 pair)	Up to 18,000 ft.	data, voice, video, video on demand
VDSL	Very high data rate digital subscriber line	13 – 52 Mbps 1.5 – 2 Mbps	downstream upstream (1 pair)	Up to 1000 – 5000 ft.	Same as ADSL plus HDTV

DSL Installation & Test

Major issues associated with DSL include the following:

- load coils
- excessive bridged tap length (unterminated stubs of twisted pair)
- too much attenuation
- too much noise or external interference (e.g. AM radio stations)
- Crosstalk from other services in the same cable bundle
- interference between POTS (plain old telephone service) and data signals
- data rate performance limits

To qualify the copper plant, a Transmission Impairment Measurement Set (TIMS) is used to measure line loss, noise, balance, return loss and impedance. A Time Domain Reflectometer (TDR) is used to measure cable length and to locate faults such as bridged taps.

A test set that contains a built-in ATU-R “golden modem” transmits and receives data over the circuit under test and determines the transmission capacity of the link.

To verify the end-to-end throughput performance of the system, an IP test set connected to the Ethernet interface should be used.

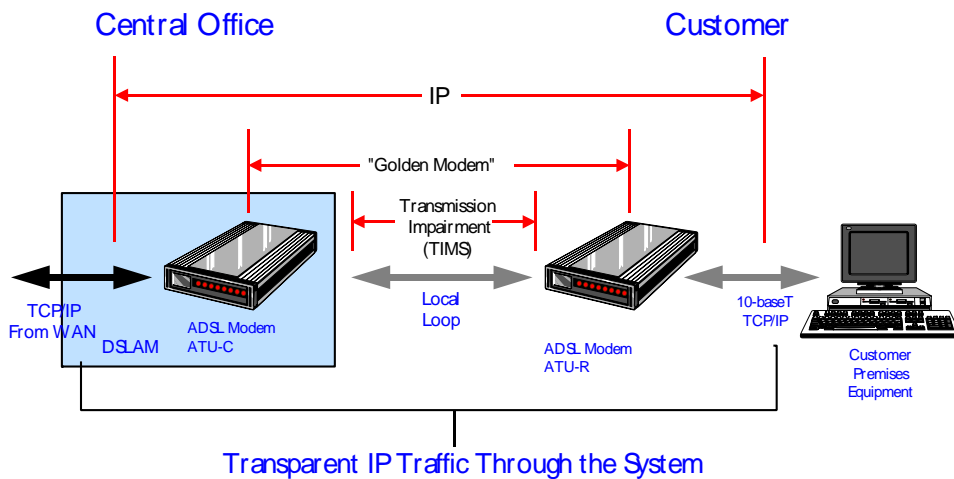

Figure 3: The required DSL measurements can be performed using test sets such as the Agilent N1625A TIMS, the Agilent Presto (golden modem) the Agilent FrameScope 350 IP performance analyzer.

Hybrid Fiber Coax (HFC)

Hybrid fiber coax (HFC) is the broadband distribution network used by cable TV operators (figure 4). Signals are carried from the head end to the customer premise over a combination fiber optic cable and coaxial cable. Cable TV operators use the wide bandwidth of 5 to 750 MHz to carry analog and digital TV, high speed Internet access via cable modems and telephony.

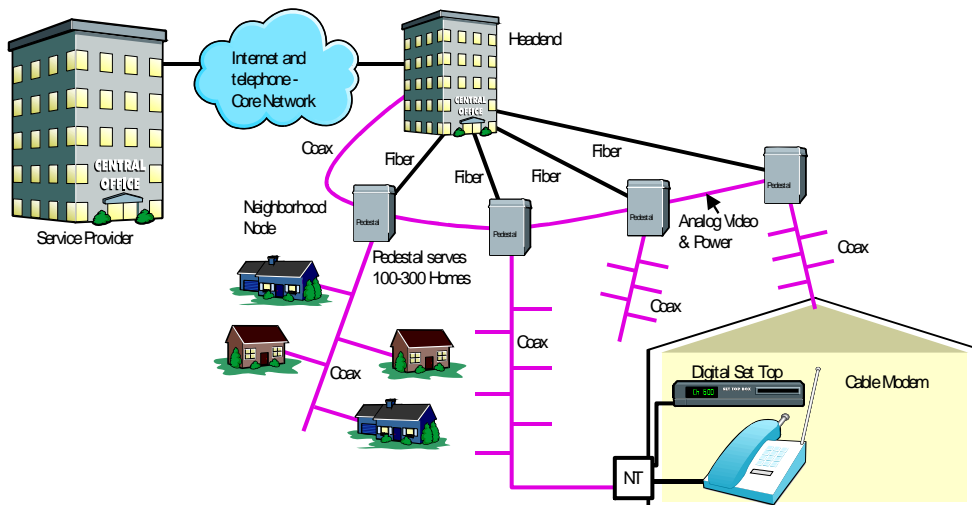

Figure 4: HFC architecture. The fiber extends from the head end to a pedestal. At the pedestal the signals are converted to electrical and complete the run to the end users over the conventional 75-ohm coaxial cable.

The frequency range from 50 to 750 MHz is used for analog and digital TV and is organized into 6 MHz channels. Traditional analog TV requires the entire 6 MHz channel while the emerging digital TV can support 4 to 6 programs per channel.

The frequency range from 5 to 50 MHz, called the reverse or return path, is used for the transmission of signals from user to headend. Reverse path applications include upstream transmission from cable modems and commands from interactive TV set top boxes. Bi-directional telephony service also resides in this band.

HFC Installation & Test

The cable plant must be aligned so that the signal levels are uniform across the band. To verify proper signal levels, cable sweep is performed to measure attenuation and to find faults in the passive components, splitters and taps. The signal level of each analog channel and the power level of each digital channel must also be measured. Ambient ingress noise and spurious signals must be measured to ensure the performance of HFC networks. Ingress is greater in the reverse path because noise accumulates from multiple user taps and because more sources of interference are present in the frequency band of 5 to 50 MHz. These loss, signal level, power and noise measurements can be performed by analyzers such as the Agilent CaLan 2010B/3010 or the Cable Advisor.

Losses in the optical portion of the network are measured using an optical power meter. To locate major cable faults, such as breaks and water infiltration, optical and metallic TDRs are used.

A set of analog TV measurements known as “proof-of-performance” ensures the quality of TV signals. These measurements look at signal distortion and at the levels of AM and FM modulation. To qualify digital signals such as data and digital TV, cable operators need to characterize the digital modulation. The type of digital modulation used in HFC networks is Quadrature Amplitude Modulation (QAM). The important measurements of a QAM signal include Modulation Error Ratio (MER) and Bit Error Ratio (BER). MER is a type of signal-to-noise ratio. BER is the measure of error rate in the data stream. The QAM signal may be viewed graphically in a “constellation” display shown in figure 5.

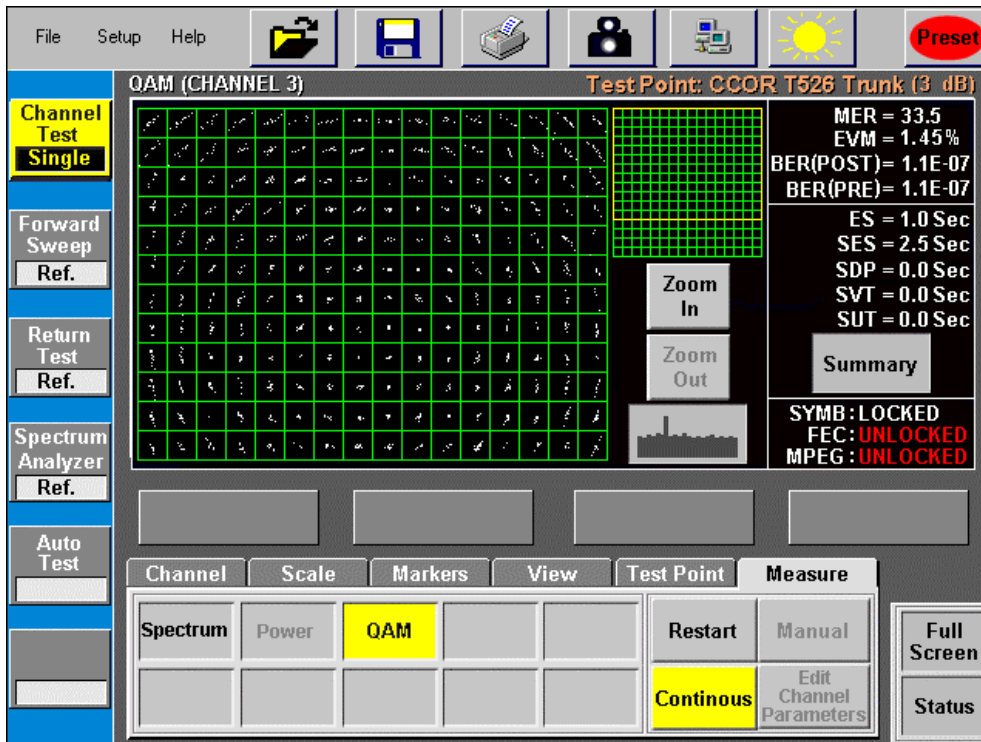

Figure 5 – QAM Measurements performed by the Agilent Cable Advisor showing a constellation display and the associated MER and BER measurements.

End-to-End Protocol Testing

The performance of Broadband data access is of great importance to users with critical Internet applications such as e-commerce or financial services. Typically, throughput and responsiveness of broadband access is measured between Ethernet networks end-to-end. Such performance testing can be done using a hand-held Ethernet analyzer optimized to verify throughput and responsiveness of common network devices such as Web and File servers.

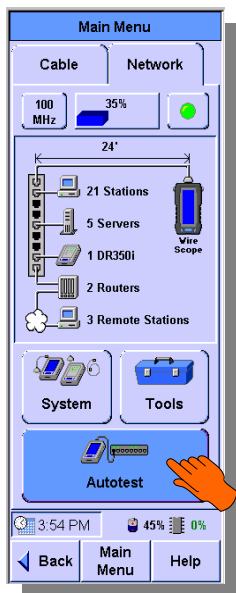

Figure 6: Some hand-held network analyzers offer easy-to-use performance tests. The FrameScope 350 analyzer from Agilent technologies features an Autotest tool. Autotest is designed to verify the performance of common data services and can be an indispensable verification tool for the technicians who install broadband access.

Summary

Now is a good time for network installers to get up to speed on the emerging broadband technologies such as DSL and HFC. DSL and HFC are expected to bring voice, data and video to the homes and businesses over a single broadband connection – DSL over telephone wires and HFC over cable TV coax. Installation and testing issues associated with the deployment of these technologies range from cable quality to protocol level performance. The right test tools can guide even inexperienced installers through testing and troubleshooting at each phase of the broadband access qualification.